



*The SDW-3,5T suction unit can be towed by a 3,5 tonnes vehicle on public roads.*

## Suction Unit SDW-3,5T Diesel

***The SDW-3,5T suction units meet the high demands from the industry due to its efficiency, reliability, ease of operation and maintenance giving excellent value for money.***

The SDW is a mobile suction unit to be towed by vehicle, especially designed for dust free filling directly into big-bag via valve connection. To be operated with an up to 5" wide hose connection.

The units main components are; trailer, housing for vacuum pump and diesel engine, hopper bin, filter compartment, hydraulic operated elevating equipment for hopper and control cabinet.

- Mobile suction unit for public road transport
- Dust free filling into big-bag
- Filter system, for dry and wet material
- Automatic filter cleaning without compressed air
- Powered by diesel engine 45 kW Stage IIIA
- Easy to operate and maintain
- Telescopic adjustable legs for flexible dust discharge

### **WHY SDW-3,5T**

More and more applications require a fast and safe handling of dust that has to be taken care of. Also regulations regarding dust exposure for personnel operating vacuum units are getting more rigid in most countries.

The SDW-3,5T unit meets these demands; easy to move from one site to the next, access into narrow areas, easy handling dust free filling direct into big-bag, high capacity using Roots pump, low noise level due to sound insulated housing.

### **OPERATION**

Vacuumed material is transported via a flexible hose to the hopper bin inlet, where all heavier particles fall by gravity to the bottom of the conical hopper bin. A specially designed wear inlet ensures reliable operation. Lighter dust particles are settled on the filter surface, and fall to the bottom of the hopper during the automatically repeated filter cleaning sequences.

The hopper compartment is emptied through an hydraulically operated slide valve. Under the valve a flange connection is mounted for dust free discharge of material into big-bag. For discharging into other, hopper or other receivers, the height of the hopper bin is easily adjusted using the hydraulic elevating system.

The unit can also operate as a central vacuum cleaning unit connected to a fixed pipe network.

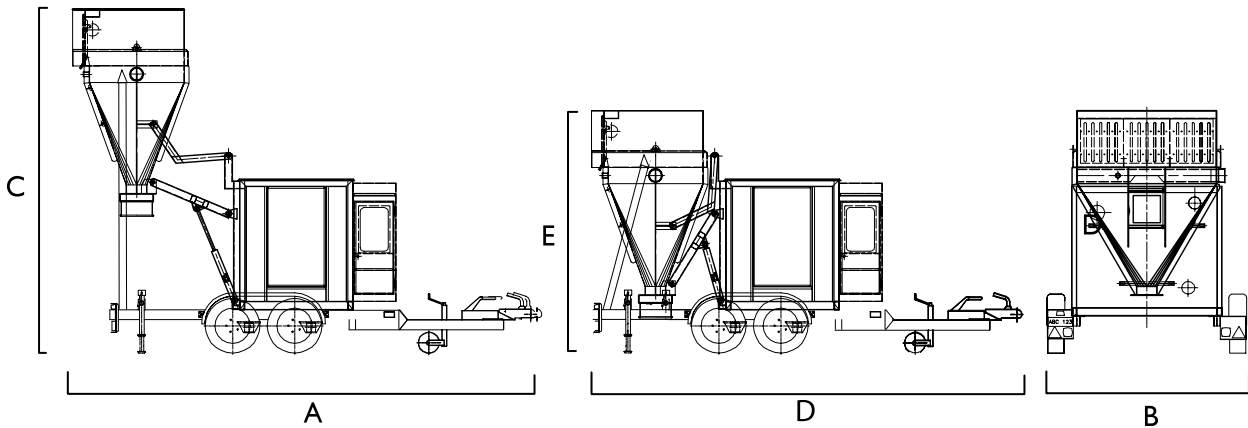

## Suction Unit SDW-3,5T Diesel

### VACUUM PUMP

The vacuum producer is of the Roots pump type, driven via V-belt transmission by an air-cooled diesel engine. Pump and engine are mounted on a anti vibrated steel structure, which also acts as the exhaust air silencer.

The vacuum pump is equipped with a spring-loaded safety valve, regulating the vacuum not to exceed its maximum operating range. For extra protection of the vacuum pump, high temperature sensor and safety filter are installed.

For service, the unit is fitted with large access doors on both sides.

### FILTER SYSTEM

The main filter compartment contains a cassette filter with flat filter bags, made of specially treated polyester needle felt. Service of filters is easy from the clean air side and from outside of the unit. The filter system is equipped with a vacuum controlled ATM (air-repulse) filter cleaning system. When activated, a large air inlet will ensure a fast backwards air direction through the filters, thus in an efficient way knocking off collected dust from the filter surface.

### DUST BIN

Type: Conical hopper  
Bin Volume: 1,0 m<sup>3</sup>  
Discharge valve: 250 mm, hydraulically operated slide valve  
Big bag connect: 320 mm, with relief filter.  
Lifting system: Hydraulically 3,7 tonnes capacity

### CONTROLS - SAFETY FUNCTIONS

All functions are automatically controlled from the control panel, and accessible from outside the unit. Engine Automatic Shut-down:

- Oil pressure too low
- Engine temperature too high

Automatic Vacuum Relief Valves Opens:

- Exhaust air temperature from vacuum pump too high
- At alarm from bin-level control (opt)
- At alarm from DP-switch filters (opt)

### MISCELLANEOUS

Electrical System: 12 V DC, battery and charger.  
Hose Connection: 152 mm  
Diesel Tank Volume: 40 l  
Towing Connection: 50 mm, steel ball  
Trailer Brakes: Overrunbrake incl. lighting  
Filter class: L,M IEC EN 60335-2-69  
Material: Steel S 235 JG2  
Painting: System C2, RAL 3003 red

### OPTIONS

DP-Gauge: Safety Filter  
DP-Switch; Safety Filter  
Level Control; Paddle type (12V DC)  
Radio Remote Control (CE, Carrier wave interrupter)  
Stand-by Heater 230V

Item/Model	SDW-3,5T.45
Dimensions, in operation (AxBxC) mm	5650x2290x4055
Dimensions, in transport (DxBXE) mm	5320x2290x2740
Weight, kg (approx)	3500
Max Vacuum, mbar	500
Air Volume m <sup>3</sup> /h (unloaded)	2650
Engine Power, kW	46
Engine Emission EU/EG 97/68 (step IIIA)	Yes
Main filter surface, m <sup>2</sup>	13
Safety Filter Surface, m <sup>2</sup>	8
Noise Level dB(A) (at 5 m distance)	80
Hose Pipe Connection, dia.mm	152
Layout	F-31144

We reserve the right to alter any specifications without prior notice

#### Manufacturer:

**DISAB-TELLA AB**  
Cedersdalsvägen 1  
SE-186 40 Vallentuna  
Sweden

Tel: +46 (0) 8 514 505 70  
Fax: +46 (0) 8 511 754 66  
E-mail: industrial@disab.com  
www.disab.com

#### Distributor: