

*The TrailerVac SDT-10T suction units are equipped with built-in hydraulic tipping system and are towed/connected to i.e. a tractor*

## TrailerVac SDT-10T

***The TrailerVac SDT-10T suction units meets the industry's high demands on efficiency, reliability, ease of operation and maintenance giving excellent value for money.***

The TrailerVac SDT-10T units are a series of mobile, diesel powered vacuum loaders fitted onto trailer chassis. Dry material as well as liquids can be handle. Together with a fixed pipe network they can not only operate as a perfect central vacuum unit for industrial installations, but also as a single vacuum loader with a 4-5" hose.

- Rigid design for industrial use
- Roots-type high vacuum pump (50-80%)
- Filter system for dry and wet material
- Automatic filter cleaning without compressed air
- Donkey engine
- Engine power 45 to 55 kW.
- Large dustbins with tailgate for easy discharge

### **WHY TrailerVac SDT-10T**

Most heavy industry sites have production, raw material handling, packing etc. in several buildings/domestic areas with some distance between the premises. Therefore an ordinary stationary central vacuum cleaning system is not the optimum solution. Instead the TrailerVac SDT-10T is the perfect choice. The large collecting hopper placed on a trailer for towing by a tractor or similar makes the whole unit easy to transport. The unit can start operating as soon as a hose/pipe is connected. Also the dust handling is easily carried out as there is a built-in tipping cylinder for the discharge.

The rigid trailer can carry high load and together with high suction capacity using Roots pump the unit is especially suited for heavy industrial environments.

### **OPERATION**

The vacuumed material is first separated in a specially designed fall chamber with a wear proof pre-separator inlet.

In this section the heavier particles fall to the bottom of the container. From this section the air is then diverted to the main filter section where residual fine dust is separated. From the filter section the air passes a safety filter before entering the vacuum pump and finally a silencer before exhaust.

The well insulated motor compartment housing ensures a low noise level of the unit.

An unloading valve is placed between the main filter system and the vacuum pump. The vacuum is immediately equalised when the valves opens. At the same time the main filters are being cleaned. This also prevents counter-rotation of the engine as well as less power consumption at starting. It can also be activated by safety control functions.

All functions are operated through the dust-tight control panel which contains control lamps indicating operational status of the unit.

### **APPLICATIONS**

For any application where collection of dust is required, i.e. cleaning out deep pits, trenches, bucket elevators, conveyor spills, overhead cranes and runways, dust collectors, processing machines etc.

The unit is particularly suitable for collecting bulky or fibrous material thanks to the convenient discharging.

### **USERS**

Manufacturers of Cement, Lime, Gypsum, Tiles, Ceramics, Chemicals, Plastics, Fertilizers and Alumina.  
Foundries, Steel mills, Quarries, Mines, Pulp- and Paper Industry, Incineration Plants, Thermo-electric Power Plants, Painting Contractors/Shipyards, Cleaning Contractors...

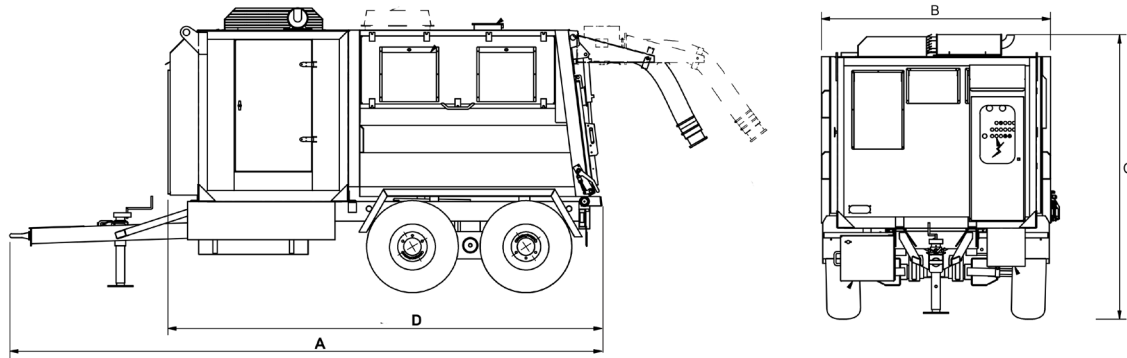

## TrailerVac SDT-10T

### VACUUM PUMP

Vacuum is generated by a pump of the Roots type, driven via V-belt transmission by a diesel engine. Pump and engine are mounted on same vibration free steel structure, which also acts as an exhaust air silencer.

The vacuum pump is equipped with a spring-loaded safety valve, preventing the vacuum to exceed its maximum operating range. For extra protection of the pump, the unit comes with a high temperature sensor and a safety filter. For easy access and service, the unit is fitted with large doors on both sides.

### FILTER SYSTEM

The main filter compartment contains a cassette filter with flat filter bags, of specially coated polyester needle felt. Service of filters is easy from the clean gas side and from outside of the unit.

The filter system is equipped with a vacuum controlled ATM (air-repulse) filter cleaning system. When activated, a large air inlet will ensure a fast backwards air direction through the filters, efficiently knocking off collected dust from the filter surface.

### DUST BIN

Type: Square container. Extra measures for water proof closing has been taken.

Air Volume: 4.0 m<sup>3</sup>

Bin level control of paddle type

### CONTROLS SAFETY FUNCTIONS

All functions are automatically operated from the control panel, and accessible from the outside of the unit. The machine is equipped with a run time meter to guide the user in necessary service and maintenance measures.

#### Engine Automatic Shut-down:

- Oil pressure too low
- Engine temperature too high

#### Automatic Vacuum Relief Valves Open:

- Exhaust air temperature from vacuum pump is too high
- Alarm from bin-level control
- Alarm from DP-switches filters (option)

### MISCELLANEOUS

Hose connect:	Dia 152 mm or smaller
Filter class:	L,M IEC EN60335-2-69
Max towing speed:	40 km/h
Electrical System:	12V DC, battery and charger
Diesel Tank Volume:	180 L
Trailer:	10 tonne capacity
Tipping cylinder:	Hydraulically 8 tonnes capacity
Material:	Steel S235 JG2
Painting:	Exterior System C2 RAL 3003 red

### OPTIONS

- BIN Painted inside
- DP-Gauge: Safety Filter
- DP-Switch; Safety Filter
- Extra Noise Insulating ATM Valve
- Hydraulic Cylinder Locking Tailgate
- Hydraulic Unit for Hydraulic Control
- Inlet Hose and Connector ( app. 1,5 m)
- Level Control; Paddle type (12V DC)
- Lugs for Crane
- Radio Remote Control (CE, Carrier vave interr.)
- Stand-by Heater 230V
- ATEX max ST1 Outdoor Execution , according to CE

On request, the unit can also be supplied on a frame for local assembly onto specified truck chassis.

Item / Model	TrailerVac SDT-10T	10T.45	10T.55	10T.55 80%
Dimensions, mm A	5420	5420	5420	5420
B	2100	2100	2100	2100
C	2700	2700	2700	2700
D	4000	4000	4000	4000
Weight, kg (approx)	4400	4900	5000	5000
Max. Vacuum, mbar	500	500	800	800
Air volume, m <sup>3</sup> /h (unloaded)	2650	3020	2060	2060
Engine Power, kW	48	58	58	58
Engine Emissions 97/68/EC (step3A)	Yes	Yes	Yes	Yes
Main Filter Surface, m <sup>2</sup>	18	18	18	18
Safety Filter Surface, m <sup>2</sup>	10	20	10	10
Noise level dB(A) (at 5 m distance)	75	77	77	77
Lay-out				SD-10056

We reserve the right to alter any specifications without prior notice

#### Manufacturer:

**DISAB-TELLA AB**  
Cedersdalsvägen 1  
SE-186 40 Vallentuna  
Sweden

Tel: +46 (0) 8 514 505 70  
Fax: +46 (0) 8 511 754 66  
E-mail: industrial@disab.com  
www.disab.com

#### Distributor: