

DISAB Industrial Vacloaders

The TrailerVac SDT-10T suction units are equipped with built-in hydraulic tipping system and are towed/connected to i.e. a tractor.



This unit is equipped with ATEX-solution as an extra option.

TrailerVac SDT-10T/SDTX-10T

The TrailerVac SDT-10T suction units meets the industry's high demands on efficiency, reliability, ease of operation and maintenance giving excellent value for money.

The TrailerVac SDT-10T units are a series of mobile, diesel powered vacuum loaders fitted onto trailer chassis. Dry material as well as liquids can be handle. Together with a fixed pipe network they can not only operate as a perfect central vacuum unit for industrial installations, but also as a single vacuum loader with a 4-5" hose.

- Rigid design for industrial use
- Roots-type high vacuum pump (50-80%)
- Filter system for dry and wet material
- Automatic filter cleaning without compressed air
- Water cooled engine
- Engine power 55 kW.
- Large dustbins with tailgate for easy discharge

WHY TrailerVac SDT-10T

Most heavy industry sites have production, raw material handling, packing etc. in several buildings/domestic areas with some distance between the premises. Therefore an ordinary stationary central vacuum cleaning system is not the optimum solution. Instead the TrailerVac SDT-10T is the perfect choice. The large collecting hopper placed on a trailer for towing by a tractor or similar makes the whole unit easy to transport. The unit can start operating as soon as a hose/pipe is connected. Also the dust handling is easily carried out as there is a built-in tipping cylinder for the discharge.

The rigid trailer can carry high load and together with high suction capacity using Roots pump the unit is especially suited for heavy industrial environments.

OPERATION

The vacuumed material is first separated in a specially designed fall chamber with a wear proof pre-separator inlet.

In this section the heavier particles fall to the bottom of the container. From this section the air is then diverted to the main filter section where residual fine dust is separated. From the filter section the air passes a safety filter before entering the vacuum pump and finally a silencer before exhaust.

The well insulated motor compartment housing ensures a low noise level of the unit.

An unloading valve is placed between the main filter system and the vacuum pump. The vacuum is immediately equalised when the valves opens. At the same time the main filters are being cleaned. This also prevents counter-rotation of the engine as well as less power consumption at starting. It can also be activated by safety control functions.

All functions are operated through the dust-tight control panel which contains control lamps indicating operational status of the unit.

APPLICATIONS

For any application where collection of dust is required, i.e. cleaning out deep pits, trenches, bucket elevators, conveyor spills, overhead cranes and runways, dust collectors, processing machines etc.

The unit is particularly suitable for collecting bulky or fibrous material thanks to the convenient discharging.

USERS

Manufacturers of Cement, Lime, Gypsum, Tiles, Ceramics, Chemicals, Plastics, Fertilizers and Alumina.
Foundries, Steel mills, Quarries, Mines, Pulp- and Paper Industry, Incineration Plants, Thermo-electric Power Plants, Painting Contractors/Shipyards, Cleaning Contractors...

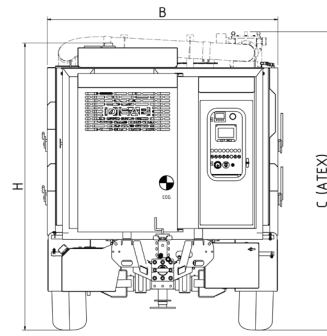
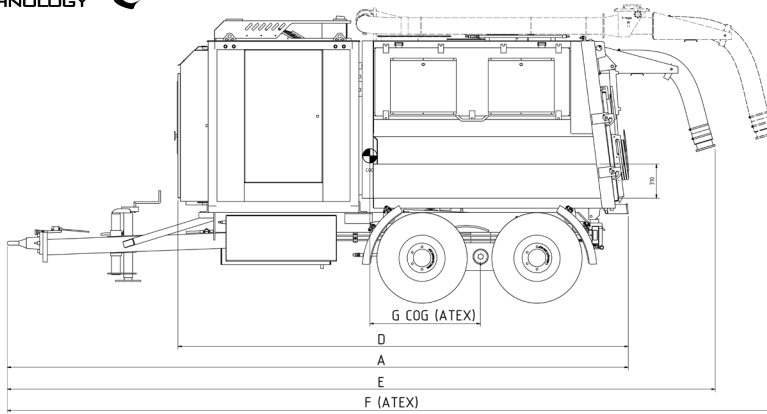

TrailerVac SDT-10T/SDTX-10T

VACUUM PUMP

Vacuum is generated by a pump of the Roots type, driven via V-belt transmission by a diesel engine. Pump and engine are mounted on same vibration free steel structure, which also acts as an exhaust air silencer.

The vacuum pump is equipped with a spring-loaded safety valve, preventing the vacuum to exceed its maximum operating range. For extra protection of the pump, the unit comes with a high temperature sensor and a safety filter. For easy access and service, the unit is fitted with large doors on both sides.

FILTER SYSTEM

The main filter compartment contains a cassette filter with flat filter bags, of specially coated polyester needle felt. Service of filters is easy from the clean gas side and from outside of the unit.

The filter system is equipped with a vacuum controlled ATM (air-repulse) filter cleaning system. When activated, a large air inlet will ensure a fast backwards air direction through the filters, efficiently knocking off collected dust from the filter surface.

DUST BIN

Type: Square container. Extra measures for water proof closing has been taken.

Volume: 4.0 m³

Bin level control of paddle type

CONTROLS SAFETY FUNCTIONS

All functions are automatically operated from the control panel, and accessible from the outside of the unit. The machine is equipped with a run time meter to guide the user in necessary service and maintenance measures.

Engine Automatic Shut-down:

- Oil pressure too low
- Engine temperature too high
- Low fuel level

Automatic Vacuum Relief Valves Open:

- Exhaust air temperature from vacuum pump is too high
- Alarm from bin-level control
- Alarm from DP-switches filters (option)

MISCELLANEOUS

Hose connect: Dia 152 mm or smaller
 Filter class: L,M IEC EN60335-2-69
 Max towing speed: 40 km/h
 Electrical System: 24V DC, battery and charger
 Diesel Tank Volume: 180 L

Trailer: 10 tonne capacity
 Tipping cylinder: Hydraulically 8 tonnes capacity
 Material: Steel S235 JG2
 Painting: Exterior System C2 RAL 3003 red

OPTIONS

- BIN Painted inside
- DP-Gauge: Safety Filter
- DP-Switch; Safety Filter
- Extra Noise Insulation ATM Valve
- Hydraulic Cylinder Locking Tailgate
- Hydraulic Unit for Hydraulic Control
- Inlet Hose and Connector (app. 1,5 m)
- Level Control; Paddle type
- Lugs for Crane
- Radio Remote Control (CE, Carrier vave interr.)
- Stand-by Heater 230V
- ATEX max ST1 Outdoor Execution , according to CE

On request, the unit can also be supplied on a frame for local assembly onto specified truck chassis.

Model TrailerVac SDT-10T / SDTX-10T	10T.55	10T.55 80%	X-10T.55
Dimensions, mm A	5700	5700	5700
B	2100	2100	2100
C			2750
D	4100	4100	4100
E	6500	6500	6500
F			7000
G	1000	1000	1000
H	2650	2650	
Weight, kg (approx)	5200	5300	5400
Max. Vacuum, mbar	500	800	500
Air volume, m ³ /h (unloaded)	3200	2060	3200
Engine Power, kW	55	55	55
Engine Emissions (step3b)	Yes	Yes	Yes
Main Filter Surface, m ²	18	18	18
Safety Filter Surface, m ²	10	10	10
Noise level dB(A) (at 5 m distance)	77	77	77
Towing eye load, kg	1100	1100	1100
Lay-out	204896		

We reserve the right to alter any specifications without prior notice

Manufacturer:

DISAB-TELLA AB
 Cedersdalsvägen 1
 SE-186 40 Vallentuna
 Sweden

Tel: +46 (0) 8 514 505 70
 Fax: +46 (0) 8 511 754 66
 E-mail: industrial@disab.com
 www.disab.com

Distributor: